

Gainsborough

ELECTRIC SHOWER



**A Step by Step
Guide to Installing
and Using
your shower**

Please leave with the user

Part No. GBH004 Issue 3

Service enquiries: 01959 560760

Contents			
Section 1 Safety			
1.1 User Safety Information	2	4.2 Electrical Requirements	5
1.2 General Safety	3	4.3 Siting Considerations	7
1.3 Electrical Safety	3	4.4 Pressure Relief Device (PRD)	8
1.4 Plumbing Safety	3	4.5 Inlet fittings	8
Section 2 Introduction		Section 5 Fitting the Shower	
2.1 How the Shower Works	4	5.1 Preparation	9
2.2 Shower Components	4	5.2 Cable and Pipe Entry Options	9
2.3 Pack Contents	4	5.3 Mounting the Shower	9
Section 3 Specification		5.4 Cable Entry	11
3.1 Technical Specification	5	5.5 Pipe Entry	11
3.2 Standards and Approvals	5	5.6 Plumbing	11
Section 4 Site Requirements		5.7 Wiring	12
4.1 Water Requirements	5	5.8 Fitting the Cover	12
		Section 6 Commissioning	
		6.1 Commissioning Tests	13
		Section 7 Operator Instructions	
		7.1 To Turn On & Set Temperature ...	14
		7.2 To Turn Off	14
		Section 8 Maintenance	
		8.1 Cleaning the Handset	14
		8.2 Inspection	14
		8.3 Cleaning the Filter	14
		Section 9 Fault Finding	15
		Section 10 Guarantee and Service Policy	16
		10.1 Environmental Information	16

ALL ELECTRIC SHOWERS MUST BE INSTALLED BY A QUALIFIED PERSON FOLLOWING THE LATEST REVISION OF BS7671 (WIRING REGULATIONS) AND CERTIFIED TO BUILDING REGULATIONS. THE INSTALLATION MUST ALSO COMPLY WITH THE BUILDING REGULATIONS PART P AND THE WATER REGULATIONS. WHERE THERE IS A NEW INSTALLATION, OR A REPLACEMENT PRODUCT IS NOT IDENTICAL TO THE ONE BEING REPLACED, THE CABLE SIZES, CIRCUIT PROTECTIVE DEVICES, BONDING AND OTHER REQUIREMENTS OF THE BUILDING REGULATIONS MUST BE ASSESSED BY A (REGISTERED) QUALIFIED AND COMPETENT ELECTRICIAN, WHO SHOULD CARRY OUT THE INSTALLATION TAKING INTO ACCOUNT THE SITE CONDITIONS (see Table A - Page 7).

1. SAFETY

1.1 USER SAFETY INFORMATION

WARNING

Always check showering temperature before stepping into the shower. It will take approximately 20 seconds to reach a stable temperature.

1.1.1 Products manufactured by Gainsborough comply with British and European Standards, are safe and without risk provided they are installed, used and maintained in good working order in accordance with our instructions and recommendations.

1.1.2 This product contains a two stage thermal cut-out device. The first stage is self-resetting and operates in extremely low flow conditions when outlet temperature can become excessive. The second stage is permanent and operates to prevent the unit becoming dangerously hot. If the second stage operates, the shower must be replaced.

1.1.3 In addition to the 2 stage thermal cut out, this shower also contains a scald protection device. If a very low flow is selected by the user the scald protection device will automatically add flow through

the heater to reduce the outlet temperature.

1.1.4 For safety purposes, this shower has a phased shut off. Water will continue to run for a few seconds after switching off to dissipate any residual heat from the heat exchanger.

1.1.5 DO NOT operate the shower unit if it is frozen, or suspected of being frozen - refer to troubleshooting page 15.

1.1.6 DO NOT operate the shower unit if the spray head or spray hose becomes damaged.

1.1.7 DO NOT restrict flow out of the shower by placing the spray head in direct contact with your body.

1.1.8 DO NOT operate the shower unit if water ceases to flow during use.

1.1.9 DO NOT operate the shower unit if water has entered the inside of the shower unit because of an incorrectly fitted cover.

1.1.10 DO NOT operate the shower unit if it is damaged.

1.1.11 The shower head and spray plate and cartridge must be cleaned regularly with descalant to remove scale and debris, otherwise restrictions to the flow of the shower unit will result in higher temperatures and could also cause the Pressure Relief Device (PRD) in the shower unit to operate.

1.1.12 The handset and shower hose supplied are manufactured specifically to match the performance of the shower. Should either of these items require replacement you should contact Customer Service Department for help and advice. The use of unapproved components that may be of similar appearance may compromise both performance and safety and possibly result in damage not covered by the warranty terms.

1.1.13 This appliance is not intended for use by persons (including children) with reduced physical, sensory or mental capabilities or lack of experience and knowledge unless they have been given initial supervision or instruction concerning the use of the appliance by a person responsible for their safety.

Children should be supervised to ensure that they do not play with the appliance.

1.1.14 Soap, shampoo or shower gel must not be placed on top of the shower unit.

1.1.15 The shower unit must be switched off at the isolating switch when not in use.

1.2 GENERAL SAFETY

1.2.1 Read **ALL** of these instructions **BEFORE** fitting the shower, the end user must retain them for later use.

1.2.2 Switch off (isolate) electrical and water supplies **BEFORE** proceeding with the installation or carrying out servicing.

1.2.3 The shower unit must be mounted on a flat and even finished wall surface on top of the tiles (when applicable). **DO NOT** tile up to shower unit after fixing to wall.

1.2.4 This product is not suitable for mounting into steam rooms or steam cubicles.

1.2.5 Only use designated entry points for cable and pipe. Failure to do so will compromise safety.

1.3 ELECTRICAL SAFETY

1.3.1 All electrical maintenance/repairs/installation to the shower to be carried out by a qualified person. The installation should be certified to building regulations.

1.3.2 Before fitting the shower unit, determine that the electricity supply is

adequate; if in doubt, contact a competent electrician.

1.3.3 If upgrading to a higher kW shower, it is essential to ensure that the electrical circuit, including the wiring and isolating switches are adequate for the increased load.

1.3.4 It is advisable that, in the interests of safety, the shower and its electrical installation is checked by a competent electrician, at least every two years.

1.3.5 The installation must comply with BS 7671 'Requirements for Electrical Installations' (IEE Wiring Regulations).

1.3.6 This shower unit must be earthed.

1.3.7 Ensure all electrical connections are tight to prevent overheating.

1.3.8 Fuses and circuit breakers do not give protection against electric shock.

1.3.9 To enhance electrical safety, a 30mA residual current device (RCD) should be installed in all electric shower circuits. This may be part of the consumer unit, or a separate unit.

1.3.10 Other electrical equipment e.g. extractor fans, must not be connected to the shower or its supply circuit.

1.4 PLUMBING SAFETY

1.4.1 All plumbing maintenance/repairs/installation to the shower to be carried out by a qualified person.

1.4.2 The plumbing installation must comply with Water Regulations/Water By-laws.

1.4.3 The supply pipe must be flushed to clear debris before connecting to the shower unit.

1.4.4 **DO NOT** solder pipes or fittings within 300mm of the shower unit, as heat transfer can damage components.

1.4.5 **DO NOT** fit any form of outlet flow control (e.g. a tap) as the outlet acts as a vent for the heater.

1.4.6 **DO NOT** use excessive force when making connections to the flexible hose or spray head, finger tightness is sufficient.

1.4.7 All plumbing connections must be completed before making the electrical connections.

1.4.8 Ensure water pressure does not exceed the rating of the shower unit.

2. INTRODUCTION

2.1 HOW THE SHOWER WORKS

2.1.1 When the user starts the shower by pressing the start/stop button, the flow control lets in the water. If there is sufficient water pressure, the pressure switch will turn on the heating elements.

2.1.2 The element in the tank will start to heat the water and this takes typically 10-20 seconds.

2.1.3 By controlling the flow rate of water over the heating elements, it will be warmed up to the correct temperature. Reducing the flow rate will increase the water temperature and vice versa.

2.1.4 The following variables can affect the shower temperature once it has been set:-

- Incoming water temperature.
- Incoming water pressure.
- Mains electrical voltage.

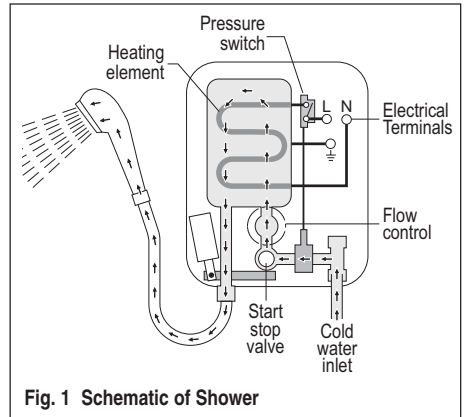

Fig. 1 Schematic of Shower

2.3 PACK CONTENTS

The shower carton contains:-

- Shower unit, knob, badge and rail.
- Shower fitting instructions and template.
- Accessory kit with fitting instructions.

Note:- Screws and wall plugs are NOT supplied.

2.2 SHOWER COMPONENTS

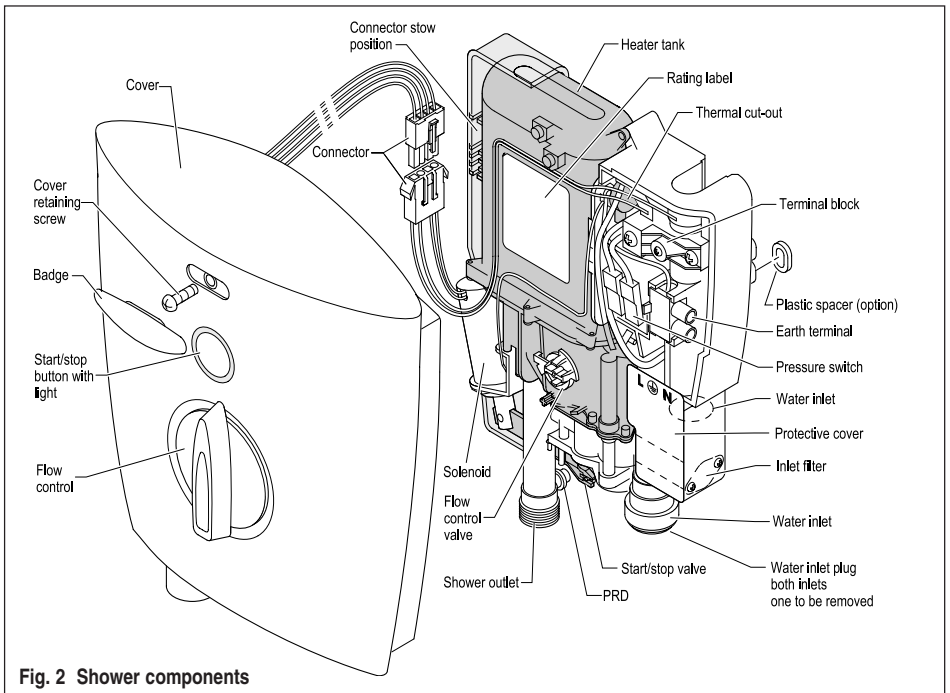

Fig. 2 Shower components

3. SPECIFICATION

Due to continuous improvement and updating, specifications may be altered without prior notice.

3.1 TECHNICAL SPECIFICATION

3.1.1 Electrical

Nominal Power Rating at 240V

8.5kW - (40A MCB rating)

9.5kW - (40A MCB rating)

10.5kW - (45A or 50A MCB rating)

Nominal Power Rating at 230V

7.8kW - (40A MCB rating)

8.7kW - (40A MCB rating)

9.6kW - (45A or 50A MCB rating)

3.1.2 Water

Minimum maintained running pressure required is 0.09MPa (0.9bar) and the maximum static pressure for the product is 1.0 MPa (10.0bar). If the pressure is below the minimum stated, contact the local water authority.

Inlet connection - 15mm diameter push fit connection.

Outlet connection - ½” BSP male thread.

Dimensions - see template.

3.1.3 Entry Points

Entry Points		Water		
		Top	Bottom	Rear
Electric	Top	✓	✓	✗
	Bottom	✓	✓	✓
	Rear	✓	✓	✓

recommended

3.2 STANDARDS AND APPROVALS

The shower complies with the requirements of EN 60335-2-35.

Ingress protection IPX4.

The shower is British Electrotechnical Approvals Board (BEAB) approved.

4. SITE REQUIREMENTS

4.1 WATER REQUIREMENTS

4.1.1 The installation must be in accordance with Water Regulations/Water Bye-laws.

4.1.2 To ensure satisfactory operation the shower unit must be connected to a water supply, with a pressure of at least 0.09MPa (0.9bar) when water flows at a rate of 8 litres per minute.

4.1.3 If the water pressure is above the maximum or below the minimum stated, contact local water authority for advice.

4.1.4 The water supply can be taken from a cold water storage cistern provided there is a minimum head of 10m above the spray head. The shower must have an independent supply from the cistern.

4.1.5 When the stated flow rates are not available, it may not be possible to achieve optimum performance from the shower unit throughout the year.

4.1.6 When the shower is installed in hard water areas a scale inhibitor may have to be fitted.

4.1.7 A dedicated servicing valve **MUST** be fitted, in an accessible location, to the mains water supply to the shower.

4.2 ELECTRICAL REQUIREMENTS

WARNING

4.2.1 SHOWER UNIT MUST BE EARTHED

4.2.2 The installation, supply cable and circuit protection must conform with BS 7671 'Requirements for Electrical Installations' (IEE Wiring Regulations). It is essential that a qualified person assesses individual site conditions in order to determine correct cable size and permissible circuit length.

4.2.3 For typical electrical installation, see fig. 3.

4.2.4 The shower must only be connected to a 230-240V ac supply.

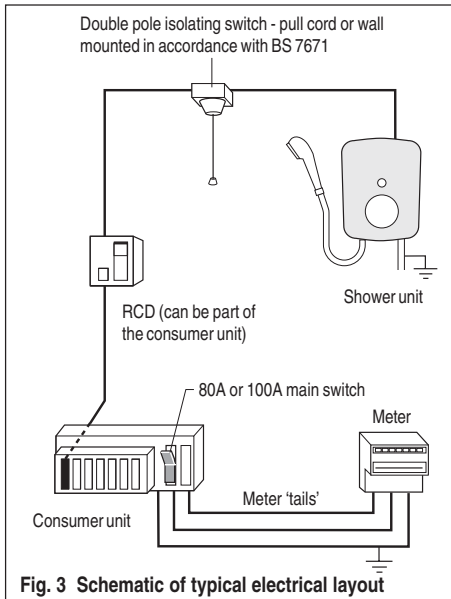

Fig. 3 Schematic of typical electrical layout

4.2.5 The electrical rating of the shower is shown on the rating label located on the heater tank - see fig. 2.

4.2.6 Before making any electrical connection within the shower installation, ensure that no terminal is live. If in any doubt, switch off the whole installation at the consumer unit.

4.2.7 The shower must be connected to its own independent electrical circuit direct from the consumer unit (fuse box). It **MUST NOT** be connected to a ring main, spur, socket outlet, lighting circuit or cooker circuit.

4.2.8 If the consumer unit has a rating below 80A or if there is no spare fuse way, then the installation will not be straightforward and may require a new consumer unit serving the whole house or just the shower unit. This should be installed by a qualified person. It may be necessary to contact the electrical supplier to upgrade the incoming supply.

4.2.9 The earthing and protective conductor arrangement within the property, in particular the supplementary bonding in the room containing the shower, must comply with BS 7671. Where additional supplementary bonding is required 4mm²

cable is recommended.

4.2.10 DO NOT use a rewirable fuse. Instead use a suitably rated miniature circuit breaker (MCB) or cartridge fuse (see table A).

4.2.11 To enhance electrical safety, a 30mA residual current device (RCD) should be installed in the shower circuit. This may be part of the consumer unit or a separate unit.

4.2.12 A suitably rated double pole isolating switch for supply disconnection must be incorporated in the fixed wiring in accordance with current wiring rules. It must have a mechanical indicator showing when the switch is in the OFF position.

4.2.13 The wiring must be connected directly to the isolating switch. A plug and socket must not be used.

4.2.14 The switch must be readily accessible and clearly identifiable in zone 3 i.e. at least 0.6 metres horizontally from the shower cubicle or edge of the bath or located above zone 2 (i.e. adjacent to the shower cubicle or bath but at least 2.25 metres from the floor). This requirement does not apply to the pull cord from the switch.

4.2.15 Where shower cubicles are located in rooms other than bathrooms, any socket

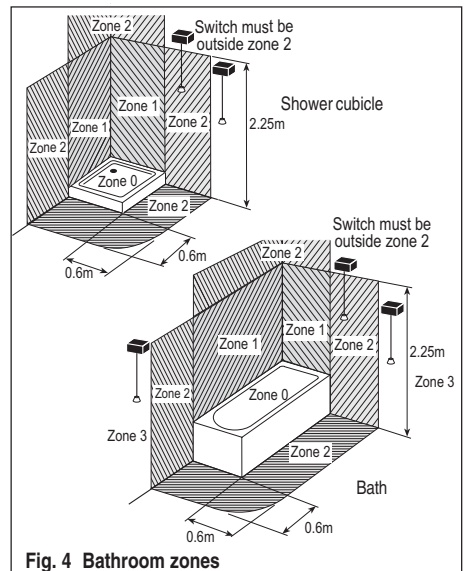

Fig. 4 Bathroom zones

Table A: Cable Current Capacity for twin and earth PVC insulated cables and Circuit Protection at 240V.

Shower rating kW @ 240V		8.5 kW		9.5 kW		10.5 kW	
Nominal current @ 240V		35.4A		39.6A		43.8A	
MCB rating		40A		40A		45/50A	
Cartridge fuse		40/45A		40/45A		45A	
		Min cable size mm ²	Max cable run in m	Min cable size mm ²	Max cable run in m	Min cable size mm ²	Max cable run in m
Type of cable run	Installed in insulated wall	10	61	10	55	10	50
	In conduit or trunking	6	37	10	55	10	50
	Clipped direct or buried in uninsulated wall	6	37	6	33	10	50

Notes:-

1. Cable selection is dependent on de-rating factors, see 4.2.19.
2. In certain installations the combination of low voltage and extended cable lengths may result in loss of power and a consequential reduction in flow rates.
3. Above cable sizes are the minimum acceptable sizes. Sizes greater than those shown above may be used and should be used if cable runs are greater than indicated (above cable runs are based on a maximum 9.6V drop).
4. Rewirable fuses are not recommended and are not covered by this table.
5. Installation should be carried out by a qualified person. Please refer to BS7671 (Wiring Regulations) if in doubt.
6. A 16mm² cable may be required for long cable runs. This should be used for rear entry applications only.

outlet in that room must be situated at least 3 metres from the shower cubicle and be protected by a 30mA RCD.

4.2.16 The current carrying capacity of the cable must be at least that of the shower circuit protection - see table A.

4.2.17 To obtain full advantage of the power provided by the shower, use the shortest cable route possible from the consumer unit to the shower.

4.2.18 The shower circuit should be separated from other circuits by at least twice the diameter of the cable or trunking.

4.2.19 The current rating will be reduced if the cabling is bunched with others, surrounded by thermal loft or wall insulation or placed in areas where the ambient temperature is above 30°C. Under these conditions, derating factors apply and it is necessary to select a larger cable size e.g. increase from 6mm² to 10mm².

4.3 SITING CONSIDERATIONS

CAUTION

4.3.1 The shower unit must not be positioned where it will be subjected to freezing conditions.

4.3.2 The shower must be mounted on a flat and even finished wall surface on top of tiles (when applicable). Do not tile up to the shower unit after fixing to the wall. The shower is spaced off the wall by integral pillars to allow air circulation.

4.3.3 Plastic spacers are provided which can be used when the wall is uneven. Spacers are taped to the inside of the cover.

4.3.4 Do not use sealants around the shower.

4.3.5 Position the unit where it will **NOT** be in direct contact with water from the spray head. Position the shower unit vertically.

4.3.6 Water Regulations/Bye-laws (shower hose connections) require the spray head to be 'constrained by a fixed or sliding

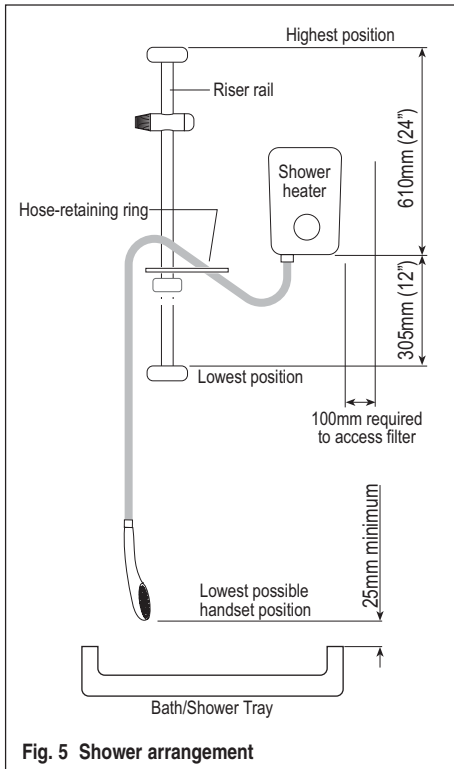

Fig. 5 Shower arrangement

Refer to template supplied for position details.

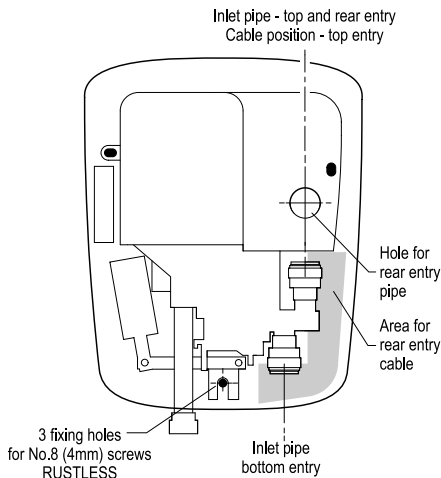

Fig. 6 Template schematic

attachment so that it can only discharge water at a point not less than 25mm above the spill-over level of the relevant bath, shower tray or other fixed appliance'. The use of the supplied retaining ring will in most cases meet this requirement, but if the spray head can be placed within a bath, basin or shower tray, then to prevent back-syphonage an alternative method should be used, such as a check valve in the supply pipe.

4.4 PRESSURE RELIEF DEVICE (PRD)

4.4.1 To meet European standards the shower unit has an integral Pressure Relief Device (PRD). The PRD provides a degree of shower unit protection should an excessive build-up of pressure occur within the shower.

4.4.2 DO NOT operate the shower with a damaged or kinked shower hose or blocked spray head, as this can cause the PRD to operate. Failure to follow this instruction will invalidate the warranty on this item.

4.4.3 The shower will only function correctly with the hose and handset provided. See separate instructions for details. Failure to do so may result in the operation of the PRD. Failure to follow this instruction will invalidate the warranty on this item.

4.4.4 When commissioning follow the procedure described in section 6.1. Failure to do so may result in the operation of the PRD. Failure to follow this instruction will invalidate the warranty on this item.

4.4.5 The shower must be positioned over a bath or shower tray because in the event of the PRD operating, water will drain from the bottom of the shower.

4.5 INLET FITTINGS

4.5.1 The two inlet fittings of the shower are plastic push fit type. To remove inlet plug or pipe from the fitting press down on two sides of the collar as shown in fig. 7.

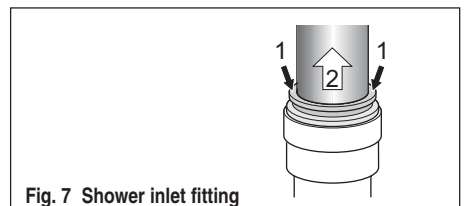

Fig. 7 Shower inlet fitting

5. FITTING THE SHOWER

5.1 PREPARATION

5.1.1 Remove cover retaining screw and carefully remove cover by pulling up the top edge. Avoid twisting, see fig. 8.

Note: Bottom of the cover is hooked onto the shower unit.

5.1.2 Lift the connector from the back plate and separate connector by pressing on the lock lever, see fig. 8.

5.1.3 Decide which entry points will be most suitable for cable and water pipe, see page 10.

5.1.4 The mounting surface should be reasonably flat and smooth. Spacers (2.5mm) are provided for use when the wall surface is uneven. The spacers should be positioned on the fixing screws between the wall and the shower unit. The shower unit must not be twisted or deflected in any way.

Note: Four spacers are taped on the inside of the cover.

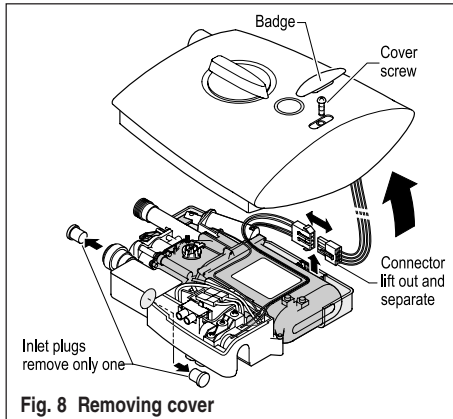

Fig. 8 Removing cover

5.2 CABLE AND PIPE ENTRY OPTIONS

Table C Entry points

Entry Points		Water		
		Top	Bottom	Rear
Electric	Top	✓	✓	✗
	Bottom	✓	✓	✓
	Rear	✓	✓	✓

recommended

5.2.1 Deviation from the designated entry points will invalidate product guarantee and may make the shower unsafe.

5.2.2 Fig. 10, page 10, shows pipe and cable entry options.

5.3 MOUNTING THE SHOWER

5.3.1 The most convenient stage at which to mount the shower on the wall will depend on the installation and the cable and pipe entry options selected. This will normally be when cable and pipe runs have been completed.

5.3.2 To obtain accurate drilling positions for the 3 mounting holes either:-

1. Use template supplied.
2. Connect shower to water pipe and mark the 3 holes.

WARNING

5.3.3 Before drilling any holes, check position of cables and water pipes within the walls.

5.3.4 Ensure shower is level, use a small spirit level on top of the unit as shown in fig. 9.

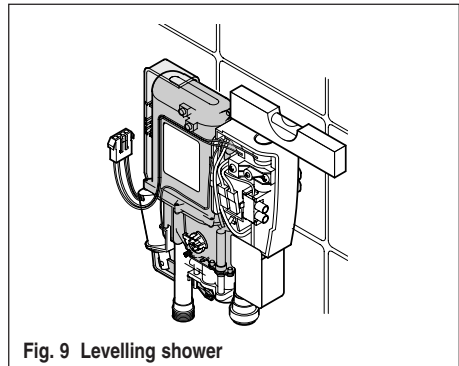

Fig. 9 Levelling shower

5.3.5 Screws and wall plugs are not supplied. Suitable screws and plugs must be selected to suit the wall type. The recommended screw size is no. 8 x 1½" (Ø4 x 40mm).

5.3.6 Remove shower from pipe, if applicable, then drill the wall and fit suitable wall plugs.

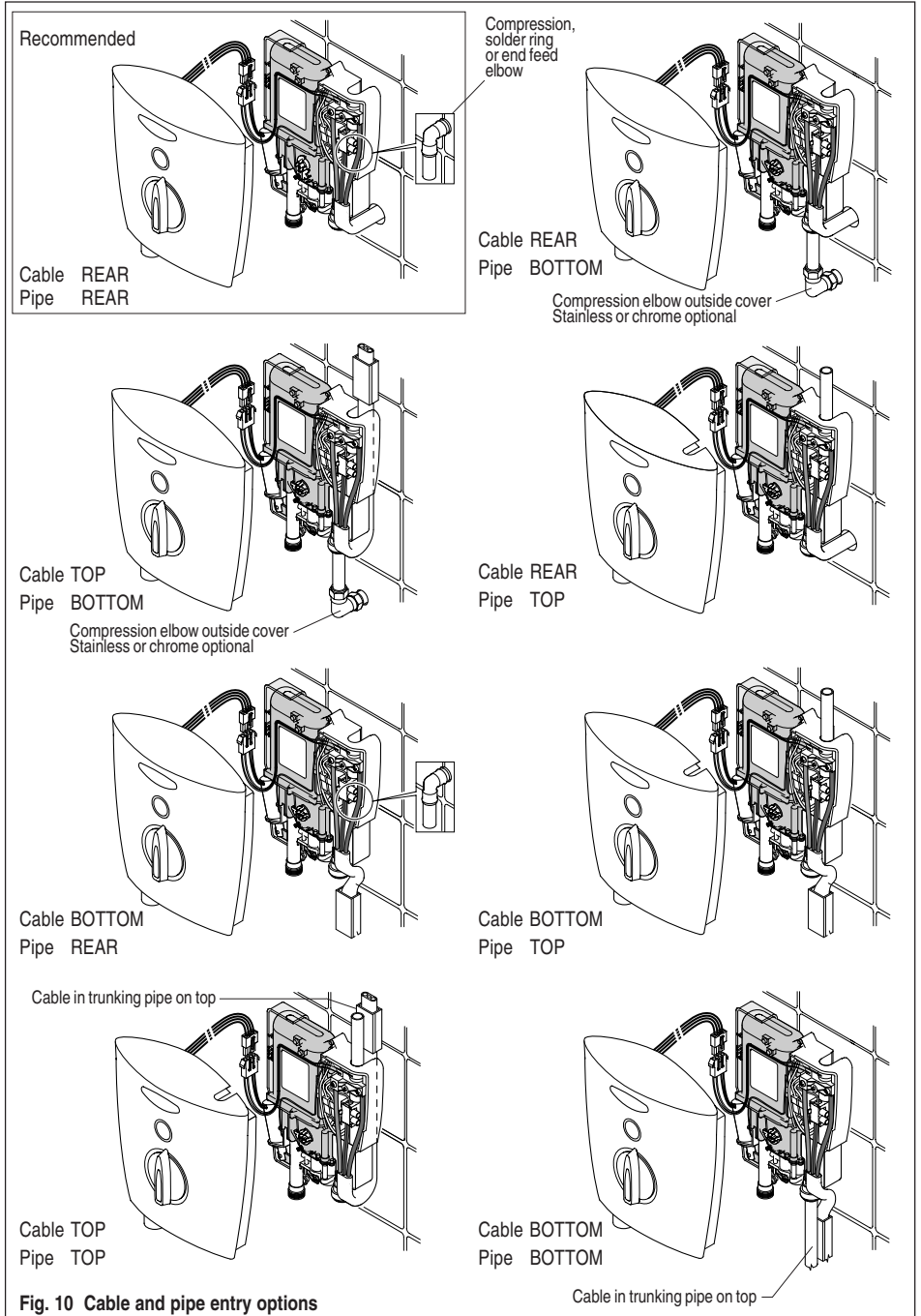

Fig. 10 Cable and pipe entry options

- 5.3.7 Connect shower to water pipe.
- 5.3.8 Screw shower to wall. Do not overtighten screws. Use spacers (taped to inside of cover) to correct uneven walls.

5.3.9 Check that the water inlet plug is correctly fitted and pushed fully home, into the inlet not being used - see fig. 8.

5.3.10 Check that the solenoid lever is free to move.

5.4 CABLE ENTRY

For cable entry options refer to page 10.

5.4.1 For rear entry, the cable must emerge from the wall only in the area specified, see fig. 5 and template.

5.4.2 For rear entry at least 280mm of cable is required protruding from the wall to allow connection to the terminal block, see fig. 11.

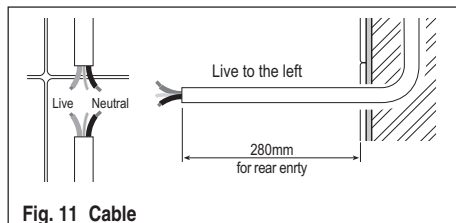

Fig. 11 Cable

5.4.3 When making cable runs, ensure that the live (red) is on the left, this will ease cable routing.

5.4.4 Cables running up the wall for bottom entry or down the wall for top entry should be enclosed in suitable plastic trunking.

5.4.5 Where both pipe and cable are arranged for top or bottom entry, the pipe should be on top of the trunking as shown in fig. 10.

5.5 PIPE ENTRY

For pipe entry options see page 10.

5.5.1 An inlet plug should be removed from the chosen inlet port - see fig. 8.

5.5.2 Concealed rear entry is considered the neatest option.

5.5.3 For concealed rear entry, solder ring, end feed or compression fittings are suitable.

5.5.4 For concealed rear entry, great care must be taken to accurately site the shower to suit the pipe position or accurately position the pipe to suit the shower position.

5.5.5 Pipes for rear entry must be 18mm from the finished wall surface and be 70mm long as shown in fig. 12.

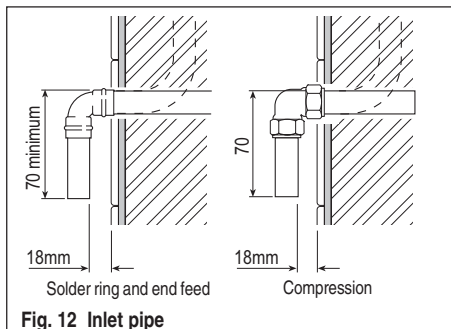

Fig. 12 Inlet pipe

5.5.6 Prior to fixing the shower unit, ensure the pipe end is clean and slightly lubricated. Silicone based lubricants or petroleum jelly are suitable.

5.5.7 Chromed pipes must have the chrome plating removed from the length of pipe that enters the showers plastic inlet connector.

5.6 PLUMBING

5.6.1 Decide where to connect to the water main for the feed to the shower. Ensure that the pipe you have selected is not a gas pipe (they can look similar) or a hot water pipe.

5.6.2 Cut the necessary pipework to length, assemble and offer up to the installation before making any soldered joints. Ensure that the pipe is the correct length, since to shorten it can be difficult once the joints have been made.

5.6.3 Carry out any cutting with pipe cutters in preference to a hacksaw, to minimise swarf and burrs.

5.6.4 Remember to incorporate a servicing valve and if required, a check valve.

5.6.5 Locate the stop cock and turn off the water supply. Check that the pipe you intend tapping into no longer carries water by opening a tap that the pipe supplies.

5.6.6 Make the connection to the pipe. If it is on a low-lying loop, there may be some water left in the pipe, so be prepared for some flow of water. Make all joints except that to the shower before flushing.

5.6.7 It is essential to flush the system before the shower is connected in order to clear any debris, bits of solder and swarf which could enter and damage components within the shower, see fig. 13.

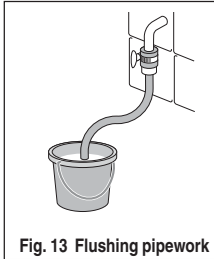

Fig. 13 Flushing pipework

5.6.8 Check for leaks in all pipework and rectify as necessary.

5.6.9 Do not use jointing compound on any pipe fittings for the shower installation.

5.6.10 Carry out all soldering on the pipe run to the shower before the shower is fitted.

5.6.11 Remove outlet cap (if fitted) and fit handset hose, refer to separate fitting instructions.

5.7 WIRING

5.7.1 **Remember, before working on electrical components, ensure they are not live.** If in any doubt, switch off at the main switch at the fuse board or consumer unit.

5.7.2 Design the system as outlined in 5.2. Lay the cable in the chosen route ensuring that you have ample length and that the live finishes on the left - refer to 5.4.3.

5.7.3 Leave the connection to the consumer unit or switch fuse until last.

5.7.4 Strip the outer insulation back as shown in fig. 14. The protective cover indicates the position for 10mm cable insulation and the minimum position for all cable sizes.

5.7.5 Cut the live, neutral and earth wires to length and strip insulation from the live and neutral wires leaving 15mm maximum bare wires. Add suitable green/yellow sleeving to earth cable leaving 10mm maximum bare cable.

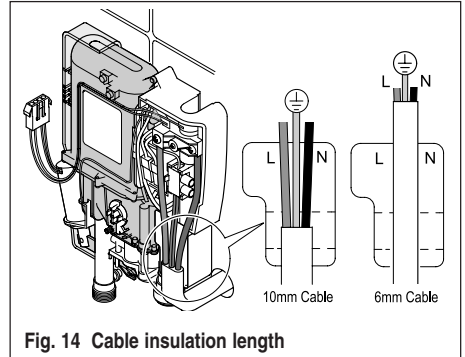

Fig. 14 Cable insulation length

5.7.6 Connections

Red or brown to live	- LEFT
Black or blue to neutral	- RIGHT
Green/yellow to earth	- CENTRE

Ensure that all terminal block screws are tight, failure to do so will result in overheating.

5.8 PREPARING THE COVER

5.8.1 When the cable and pipe connections have been made and the shower screwed to the wall, the cover may need to be cut to suit cable/pipe entry positions.

5.8.2 The cover has thinned wall sections at the designated top and bottom cable and pipe entry positions, no cutting is required for rear cable and rear pipe entry.

5.8.3 Very carefully cut the cover only at the designated positions using a junior hacksaw or side cutters. Always finish using a round file. Check that the cover fits over cables and pipes without interference.

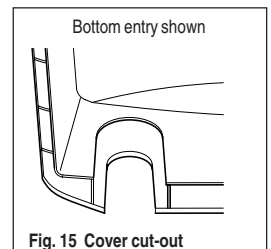

Fig. 15 Cover cut-out

6. COMMISSIONING

CAUTION

Follow the commissioning procedure exactly as failing to do so could result in damage to the shower and may void the guarantee.

6.1 COMMISSIONING TESTS

WARNING

6.1.1 Items 6.1.2 to 6.1.9 are carried out with the power OFF.

6.1.2 Once you have finished fitting the shower, carry out the following tests to ensure that the shower is functioning as it should.

6.1.3 Without fitting the shower head, secure the hose at low level where the water can discharge safely. With the electrical power turned OFF and the water supply to the unit turned ON, push the solenoid piston up until water runs through and out of the open hose then after a few seconds release, see fig. 16. The handset may now be fitted.

6.1.4 Secure the handset on the riser rail where it can spray safely. With the power turned OFF and water turned ON, push the solenoid piston up until water sprays from the shower head, then after a few seconds release, see fig 16.

6.1.5 Turn the flow control valve on the shower unit to its cold position i.e. with the lever at 6 o'clock. On the cover, turn the knob to the cold position. These two parts are keyed and must be correctly positioned in order for the cover to fit - see fig. 17.

6.1.6 Hold the cover next to the shower and carefully connect the connector, then fit the connector into its stow position at the side of the shower, neatly tucking the wires in the recess provided, see fig 18.

6.1.7 Refit the front cover by locating the lower front edge onto the shower unit then push the top back into position, ensure wires are not trapped.

6.1.8 Secure the front cover by fitting the retaining screw into the badge recess. Do not overtighten. Do not fit the badge until the shower unit has been fully tested.

6.1.9 Turn the knob and ensure it has

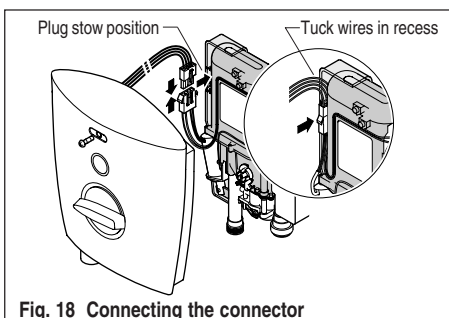
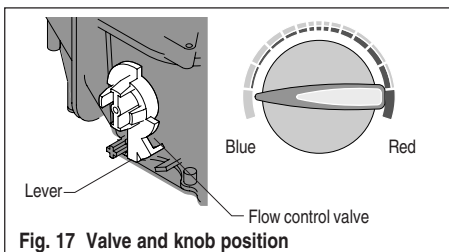
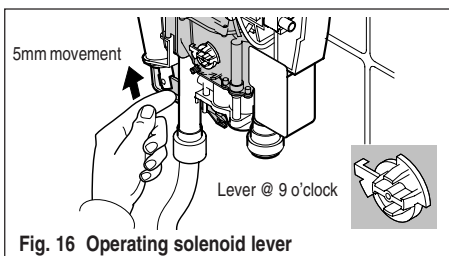

smooth movement. If resistance is felt the knob may be fitted incorrectly. Commission the shower with the knob in the mid position.

6.1.10 Turn on the electrical isolating switch. Press the stop/start button, the surround should illuminate.

6.1.11 Slowly turn the flow control knob into the red sector. The elements should now be heating and the temperature of the spray should increase.

6.1.12 Adjust the flow control knob to give the desired temperature. Allow a few seconds after each adjustment for the temperature to stabilise. A cool shower can be obtained at the extreme end of the blue sector.

6.1.13 The temperature obtained will depend on the incoming water temperature.

7. OPERATOR INSTRUCTIONS

7.1 TO TURN ON & SET TEMPERATURE

- 7.1.1 Turn on the electrical isolating switch.
- 7.1.2 Press the stop/start button, the surround should illuminate.
- 7.1.3 Turn the flow control knob.
- 7.1.4 Make adjustments carefully. Give the shower a few seconds after each adjustment to stabilise, then check the temperature by hand before stepping into the shower.

7.2 TO TURN OFF

- 7.2.1 Press the stop/start button.
- 7.2.2 Turn off the electrical isolating switch.

NOTE

7.2.3 For safety purposes, this shower has a phased shut off. Water will continue to run for a few seconds after switching off to dissipate any residual heat from the heat exchanger.

8. MAINTENANCE

8.1 CLEANING THE HANDSET

8.1.1 To maintain performance from the shower, the handset must be cleaned regularly, maybe as often as once a week in hard water areas. This is because fine holes can become restricted with scale and this will affect the pattern of the spray and cause the shower to perform poorly.

8.2 INSPECTION

8.2.1 We recommend that in the interest of safety, the shower and its electrical installation is checked by a qualified electrician at least every two years.

8.2.2 During inspection check that all electrical connections are fully tightened before replacing the cover, as loose connections may cause overheating of the terminals and product failure.

8.3 CLEANING THE FILTER

Only to be carried out by competent person.

8.3.1 To remove filter :-

1. Turn shower electrical isolating switch OFF.
2. Turn water servicing valve OFF.
3. Carefully remove badge using small screwdriver and undo cover retaining screw, pull cover away complete with knob, from the top and lift off - see fig. 8.
4. Unscrew the two screws at the side of the protective cover - see fig.19.
5. Withdraw filter element, inspect and clean.
6. Refit filter element and protective cover. The protective cover must be under the cable.
7. Refit cover - refer to 6.1.5 - 6.1.9.

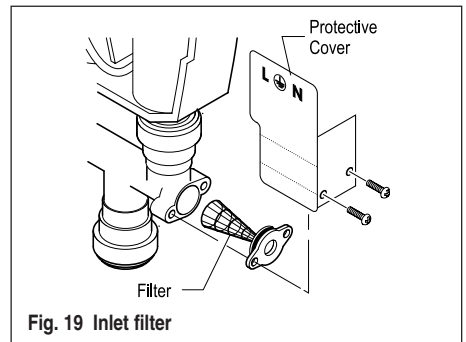

Fig. 19 Inlet filter

9. FAULT FINDING

9.1.1 In the unlikely event of a problem, consult the troubleshooting chart.

9.1.2 For the particular symptom follow the suggested remedies in the order given.

9.1.3 **IF YOU ARE UNABLE TO REMEDY THE PROBLEM WITHOUT REMOVING THE COVER, YOU SHOULD CONTACT YOUR INSTALLER OR A QUALIFIED ELECTRICIAN.**

9.1.4 Where the fault cannot be corrected by either yourself or your installer, **DO NOT REMOVE UNIT FROM THE WALL**, but

contact Customer Service Department who will try to help over the telephone. If necessary, they can arrange a visit by a service engineer. We find that the vast majority of problems can be solved by reference to these fitting instructions or by discussion over the telephone. In the event that an engineer is called and the fault is caused by faulty installation, usage, or lack of reasonable maintenance, a call-out charge will be made.

9.1.5 This shower is not suitable for use in commercial applications. Such use would invalidate warranty.

SYMPTOM	POSSIBLE CAUSE	REMEDY
1. No flow or not enough flow.	A. Power failure, light does not illuminate.	A. Check power supply, consult electrician.
	B. Water control knob is turned fully clockwise.	B. Turn flow control knob anticlockwise (3 o'clock).
	C. Water turned off at mains or servicing valve.	C. Ensure water is fully turned on at the mains and at servicing valve in supply.
	D. SHOWER UNIT SUSPECTED OF BEING FROZEN.	D. If so, DO NOT USE. (i) Switch off immediately at the electrical isolating switch. (ii) Turn water off at servicing valve (if fitted) or at stop cock. (iii) Contact our Customer Service Department.
	E. There may be an outlet blockage.	E. Disconnect handset from hose and run the shower. (i) If water flows, then handset is blocked with scale or debris. Clean the handset and spray rings/plate thoroughly. (ii) If the water does not flow, remove the hose from the shower outlet. (a) If the water flows, the hose is blocked. This could be due to damage, severe kinking or even an obstruction. Hose must be replaced with an approved hose. (b) If the water does not flow, there is a blockage in the plumbing to the shower, or the shower itself or the filter. (c) Contact Customer Service Department if the shower is considered to be the problem.
	F. Blocked inlet filter.	F. Remove filter for inspection - refer to 8.3.
	G. Restricted operation of solenoid lever.	G. Remove front cover and check operation of lever.
2. Flow adequate but water too cold	A. Water flow too high.	A. Reduce the flow by turning the flow control knob into the red section slowly.
	B. No power to unit.	B. Check isolator switched on. Check MCB or fuse at consumer unit. Check RCD (if fitted). Check 230/240V at shower terminal block. (Electrician only task)
	C. Second stage thermal trip operated.	C. This is a non-user serviceable part, shower must be replaced.
3. Water too hot.	A. Water flow too low.	A. (i) Increase flow by turning control knob into blue sector. (ii) Ensure that the stop cock and servicing valve are fully open. If so, ask the installer or the local water authority to check that the running pressure is above the minimum required - see 4.1. This may be apparent during periods of high demand or when other outlets are used.

SYMPTOM	POSSIBLE CAUSE	REMEDY
3. Water too hot cont.	B. Spray plate blocked with scale or debris.	B. Clean the handset spray plate.
	C. Water pressure too low.	C. Check with installer or local water authority.
4. Water runs from around hose.	A. PRD has operated due to excess pressure build-up.	A. Turn off the electrical isolating switch and servicing valve - contact Customer Service Department. Refer to 4.4.
	B. Hose incorrectly fitted.	B. Ensure washer is fitted and hose is correctly fitted and tight.
5. Temperature varies dramatically while showering.	A. Water pressure to shower is low or unstable.	A. Check inlet requirements, see 4.1, page 5 and ensure no other main water devices are being used whilst showering.
	B. Thermal cut-out is operating, normally making a 'click' as it does so.	B. Increase the flow by turning the flow control knob into the blue sector. Clean the handset and sprayplate.
	C. Scald protection device has activated.	C. Increase the flow by turning the flow control knob into the blue sector. Clean the handset and sprayplate.
6. Poor spray pattern. Also refer to handset instructions.	A. Multi pattern handset incorrectly set.	A. Adjust spray plate to improve pattern.
	B. Low water inlet temp.	B. Flow rate will naturally be lower when the inlet temperature is low, this applies to all electric showers.
	C. Low voltage	C. Consult electrician.

10. GUARANTEE AND SERVICE POLICY

This product is guaranteed against faulty materials and manufacture for a period of one year from the date of purchase provided that:-

1. The unit has been installed in accordance with the Installation and User Instructions and all relevant Codes of Practice and Regulations in force at the time of Installation, and that all necessary controls and safety valves have been fitted correctly.
2. The unit has not been modified or tampered with in any way, and has been regularly maintained as detailed in the Installation and User Instructions.
3. The unit has been used only for heating potable water.
4. The original proof of purchase is retained by the user in order to validate the warranty.

The unit is not guaranteed against damage by frost, and the inner container with integral heating element is not guaranteed against excessive scale build-up.

This guarantee in no way affects the statutory rights of the consumer.

The policy of Gainsborough is one of continuous product development and, as such, we reserve the right to change specifications without notice.

10.1 ENVIRONMENTAL INFORMATION

10.1.1 The Waste Electrical and Electronic Equipment (Producer Responsibility) Regulation 2004

This product is outside the scope of the European Waste Electrical and Electronic Equipment Directive as interpreted within the UK. In the UK this product can therefore be disposed of through commercial non-WEEE waste facilities.

The original manufacturer does not accept any liability under the WEEE directive.

Product serial number

'Place sticker here'

Gainsborough Showers
Seafield House,
Claylands Avenue,
Worksop,
Notts. S81 7BQ

Service

Tel: 01959 560760
Fax: 01959 560030
www.gainsboroughshowers.co.uk
email:
enquires@gainsboroughshowers.co.uk

